

■ IDM-156W

Industrial Monitor - 15.6" 1920 x 1080 LCD, RS232/USB Touch option



Features

- Industrial monitor with 15.6" wide screen LCD Panel
- 1920 x 1080 pixels, 400 cd/m2 brightness
- 6mm Aluminum bezel panel with touch screen/strengthen glass
- Rugged construction and modularized design
- VGA + HDMI/DVI + AUDIO Input signal(AV optional)
- AC 100-240V wide range external ac adapter
- DC 8 ~ 30V input power module(Optional)
- NEMA4 / IP 65 compliant front panel
- Panel (Flush) mount with bracket or standard VESA hole (100x100 mm) supports desktop stand / wall mount/ swing arm mount

Specifications

LCD Panel	
Display Type	15.6" Wide Full HD LCD
Max.Resolution	1920 x 1080
Max.color	16.7M
Luminance	400 cd/m2
View Angle	160°(H) , 140°(V)
Contrast Ratio	700:1
Response Time	8 ms
Backlight Life	50,000hrs
System & I/O Interface	
VGA	D-SUB 15Pin Connector (female)
HDMI	HDMI Input (female)
Audio	3.5" Jack
Power Connector	2-Pin Terminal Block
Display Control	OSD (Optional)
Speaker	2 x Speakers (Optional)
Available Options	
Touch screen RS232	D-SUB 9Pin connector (female)
Touch screen USB	USB-A type connector (female)

Input signal	DP, DVI-D, AV, S-video, BNC
Mechanical and Environmental	
Construction	Heavy duty steel and aluminum front panel
IP Level	Front IP65
Dimensions (WxHxD)	402x 252 x 45 mm
Weight	Net: 8.5 kg , Gross:11.5 kg
Operating temperature	-10~ 60°C (-14~140°F)
Storage temperature	-20~ 70°C (-4 ~ 158°F)
Storage humidity	5%~ 95%, non-condensing
Anti-Vibration	17HZ-500 HZ 1G PTP
Anti-Shock	1G / peak(11m sec)
Certification and Approvals	CE, FCC, ROHS
Power Supply	
Input	100~240VAC,50/60Hz
Output	DC 12V@ 5A / 60W ,external ac adapter
DC Power (Optional)	Wide Range 8~30v DC input

IDM-156W

Pictures & Views

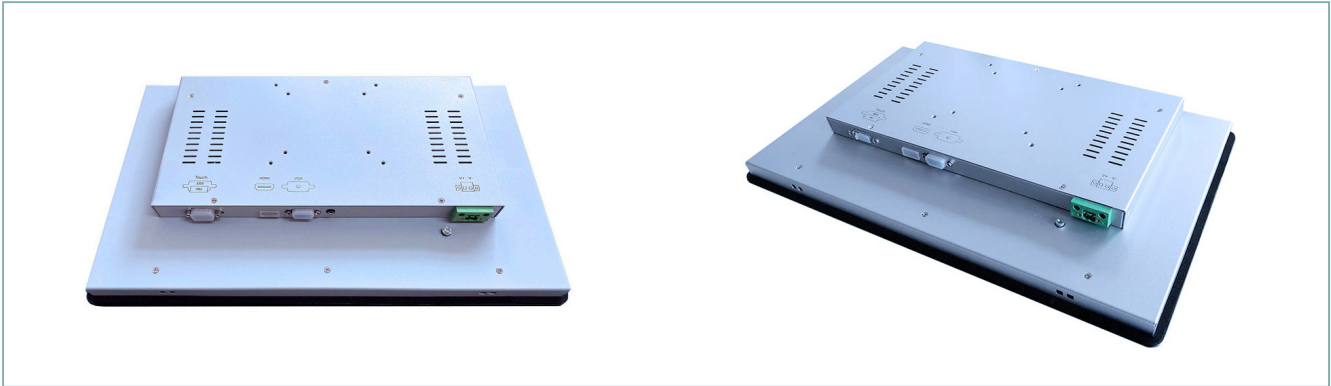

Dimensions Diagram

Dimensions (WxHxD): 402x 252 x 45 mm

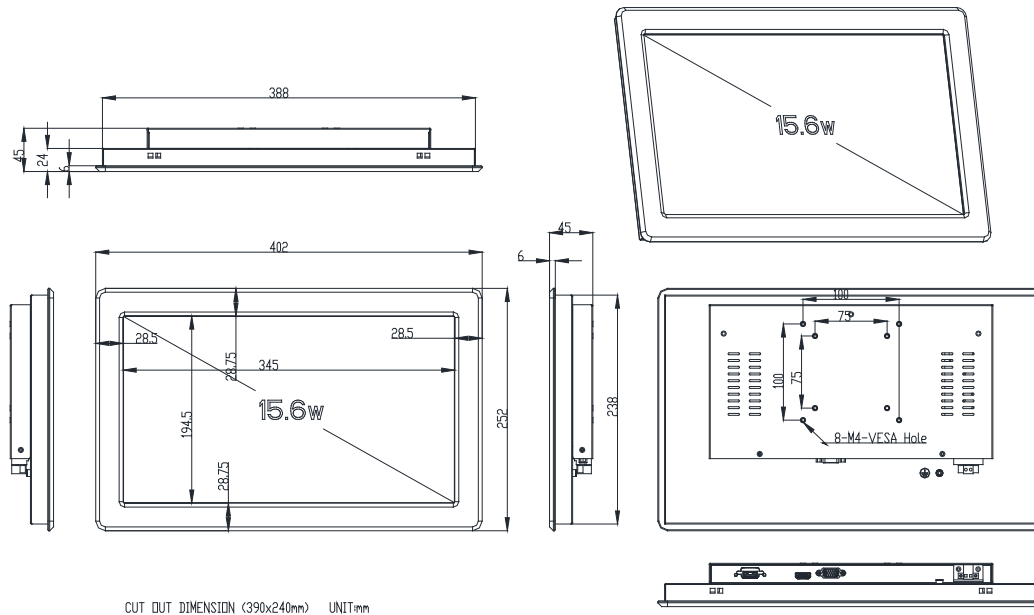

Ordering information

Model	Descriptions
IDM-156W	Industrial Monitor, 15.6" LCD Panel, wide screen, with VGA + HDMI/DVI
IDM-156WTC	Industrial Monitor, 15.6" LCD Panel, with VGA + HDMI/DVI, with touch screen and RS232 controller
IDM-156WTU	Industrial Monitor, 15.6" LCD Panel, with VGA + HDMI/DVI, with touch screen and USB controller