

High performance Industrial Panel PC

Shanghai Anxin Intelligent Technology co.,ltd

*RD,OEM and manufacture industrial computer,
industrial lcd monitor, IPC chassis, Rugged
computer, single board computer, etc.*



Contact

Tel +86-21-64377916 Fax +86-21-64377973

Email sales@anxinpc.com annxinpc@gmail.com

Address 08D Floor 10, Huijia Building, Caoxi North road NO 41, XuJiaHui, Xuhui district,
Shanghai, China

IPC-12i7

12.1" XGA TFT LCD LED Backlight Intel Core i7/i5/i3
Industrial Panel PC with Touch Screen



Features

- 12.1" TFT XGA LED Panel (1024 x 768) with resistive touch screen
- Supports Intel Core i7/i5/i3 processor
- System supports 1 x DDR3 DIMM slot ,up to 8G 1066/1333MHz SDRAM
- 6x COM (1x RS485), 1xDVI, 1x PS/2, 1xVGA, 6x2.0 USB, 2xLAN, 1x AUDIO & MIC
- Offers 1 xMini PCIe slot, for expansion
- Rear panel with power LED and HDD LED Indication, Built-in 2x 3 Watts stereo speaker
- Wireless LAN with antenna (optional), GPIO (optional)
- Robust aluminum with IP65 compliant front bezel design
- Modularize design for easy installation and maintenance

Specifications

Main System

CPU	Intel Core i7/i5/i3 Sandy bridge Processor with1066/1333 MHz FSB
Chipset	Intel H61 chipset
System Memory	1x DIMM DDR3 800/1066/1333 SDRAM up to 8 GB; Preload 2GB RAM
LAN	2x Realtek ® RL8111x (Gigabit) 10/100/1000Ethernet
HDD (hard disk)	2.5" SATA HDD; Preload 320GB HDD
Audio	Realtek ® ALC662, 5.1 channel surround audio
I/O Connector	5 x RS-232 1 x RS422/485 1x DVI-D port 1x PS/2 (Keyboard/mouse) 1x DB-15 Connector 1x Audio (Mic-in / Line-out) 2x 10/100/1000MLAN port (RJ-45) 6x USB2.0 1x 3Pin DC power input terminal block
Expansion	Mini-PCIE for wireless Lan card with antenna(Optional)

General

Construction	Aluminum front bezel and Aluminum chassis
Color	Black or OEM(>=100 units)
OS Support	Windows 7/8/10 and linux
Mounting	Panel mount or Standard VESA 75/100mm
Power supply	Input Voltage : 8~30v, with External AC adapter; Output Rating 92W
Dimensions(WxHxD)	355 x 279 x 88mm
NET weight	8.0 KG

LCD Display

Display type	12.1" XGA TFT LCD LED Backlight
Resolution	1024 x 768 pixels
Luminance	500 cd/m2
Viewing angle	160°(H) , 160°(V)

Touch screen

Controller Interface	Internal USB interface controller
Resolution	Continuous
Light Transmission	81% or more
Operating Force	≤100g
Life Expectancy	35 Million

IPC-12i7

Environment

Operating Temperature	0 ~ 50°C (32 ~ 122°F)
Storage Temperature	-20 ~ 60°C (-4 ~ 140°F)
Humidity	10% to 90%@ 40°C , on-condensing
Vibration	17 to 500HZ 1G PTP
Operating Shock	1G /peak (11m sec)
Ingress Protection	Front panel: IP65

Ordering informations

IPC-12i7	12.1 inch Industrial Panel PC with Intel i7/i5/i3 Processor, 2.5"SATA 320G HDD(or 32G SSD) , 2G RAM(4G & 8G optional), 6*COM(5* RS232.1 * 485), 1*VGA, 1* DVI,6*USB 2.0, 2*LAN, 1* Audio, 1* MIC, 1* PS2
IPC-12i7T	12.1 inch Industrial Touch Screen PC with Intel i7/i5/i3 Processor, 2.5"SATA 320G HDD(or 32G SSD) , 2G RAM(4G & 8G optional), 6*COM(5* RS232.1 * 485), 1*VGA, 1* DVI,6*USB 2.0, 2*LAN, 1* Audio, 1* MIC, 1* PS2, Resistive touch screen
CPU Description	Intel® Core™ i3-3240 Processor (3M Cache, 3.40 GHz)
	Intel® Core™ i5-3470 Processor (6M Cache, up to 3.60 GHz)
	Intel® Core™ i7-3770 Processor (8M Cache, up to 3.90 GHz)

Dimensions Diagram

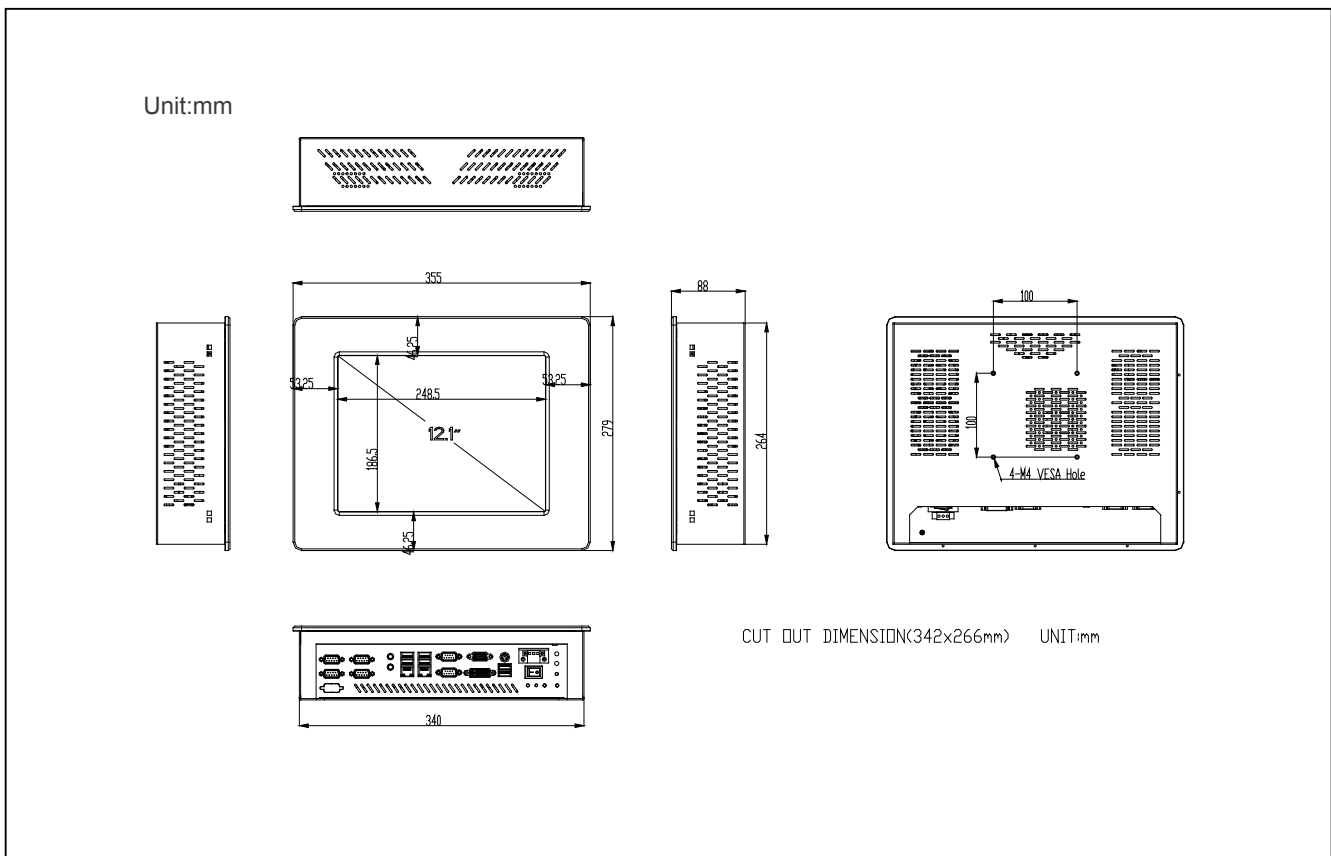

IPC-15i7

15" XGA TFT LCD LED Backlight Intel Core i7/i5/i3
Industrial Panel PC with Touch Screen



Features

- 15" TFT XGA LED Panel (1024 x 768) with resistive touch screen
- Supports Intel Core i7/i5/i3 processor
- System supports 1 x DDR3 DIMM slot ,up to 8G 1066/1333MHz SDRAM
- 6x COM (1x RS485), 1xDVI, 1x PS/2, 1xVGA, 6x2.0 USB, 2xLAN, 1x AUDIO & MIC
- Offers 1 xMini PCIe slot, for expansion
- Rear panel with power LED and HDD LED Indication, Built-in 2x 3 Watts stereo speaker
- Wireless LAN with antenna (optional), GPIO (optional)
- Robust aluminum with IP65 compliant front bezel design
- Modularize design for easy installation and maintenance

Specifications

Main System	
CPU	Intel Core i7/i5/i3 Sandy bridge Processor with1066/1333 MHz FSB
Chipset	Intel H61 chipset
System Memory	1x DIMM DDR3 800/1066/1333 SDRAM up to 8 GB; Preload 2GB RAM
LAN	2x Realtek ® RL8111x (Gigabit) 10/100/1000Ethernet
HDD (hard disk)	2.5" SATA HDD; Preload 320GB HDD
Audio	Realtek ® ALC662, 5.1 channel surround audio
I/O Connector	5 x RS-232 1 x RS422/485 1x DVI-D port 1x PS/2 (Keyboard/mouse) 1x DB-15 Connector 1x Audio (Mic-in / Line-out) 2x 10/100/1000MLAN port (RJ-45) 6x USB2.0 1x 3Pin DC power input terminal block
Expansion	1xPCI Express x16 Slot, 1 xMini PCIe slot
General	
Construction	Aluminum front bezel and Aluminum chassis
Color	Black or OEM(>=100 units)
OS Support	Windows 7/8/10 and linux
Mounting	Panel mount or Standard VESA 75/100mm
Power supply	Input Voltage : 8~30v, with External AC adapter; Output Rating 92W
Dimensions(WxHxD)	406 x 312 x 90mm
NET weight	8.5 KG
LCD Display	
Display type	15" XGA TFT LCD LED Backlight
Resolution	1024 x 768 pixels
Luminance	450 cd/m2
Viewing angle	160°(H) , 140°(V)
Touch screen	
Controller Interface	Internal USB interface controller
Resolution	Continuous
Light Transmission	81% or more
Operating Force	≤100g
Life Expectancy	35 Million

IPC-15i7

Environment

Operating Temperature	0 ~ 50°C (32 ~ 122°F)
Storage Temperature	-20 ~ 60°C (-4 ~ 140°F)
Humidity	10% to 90% @ 40°C , on-condensing
Vibration	17 to 500HZ 1G PTP
Operating Shock	1G /peak (11m sec)
Ingress Protection	Front panel: IP65

Ordering informations

IPC-15i7	15 inch Industrial Panel PC with Intel i7/i5/i3 Processor, 2.5"SATA 320G HDD(or 32G SSD) , 2G RAM(4G & 8G optional), 6*COM(5* RS232.1 * 485), 1*VGA, 1* DVI,6*USB 2.0, 2*LAN, 1* Audio, 1* MIC, 1* PS2
IPC-15i7T	15 inch Industrial Touch Screen PC with Intel i7/i5/i3 Processor, 2.5"SATA 320G HDD(or 32G SSD) , 2G RAM(4G & 8G optional), 6*COM(5* RS232.1 * 485), 1*VGA, 1* DVI,6*USB 2.0, 2*LAN, 1* Audio, 1* MIC, 1* PS2, Resistive touch screen
CPU Description	Intel® Core™ i3-3240 Processor (3M Cache, 3.40 GHz)
	Intel® Core™ i5-3470 Processor (6M Cache, up to 3.60 GHz)
	Intel® Core™ i7-3770 Processor (8M Cache, up to 3.90 GHz)

Dimensions Diagram

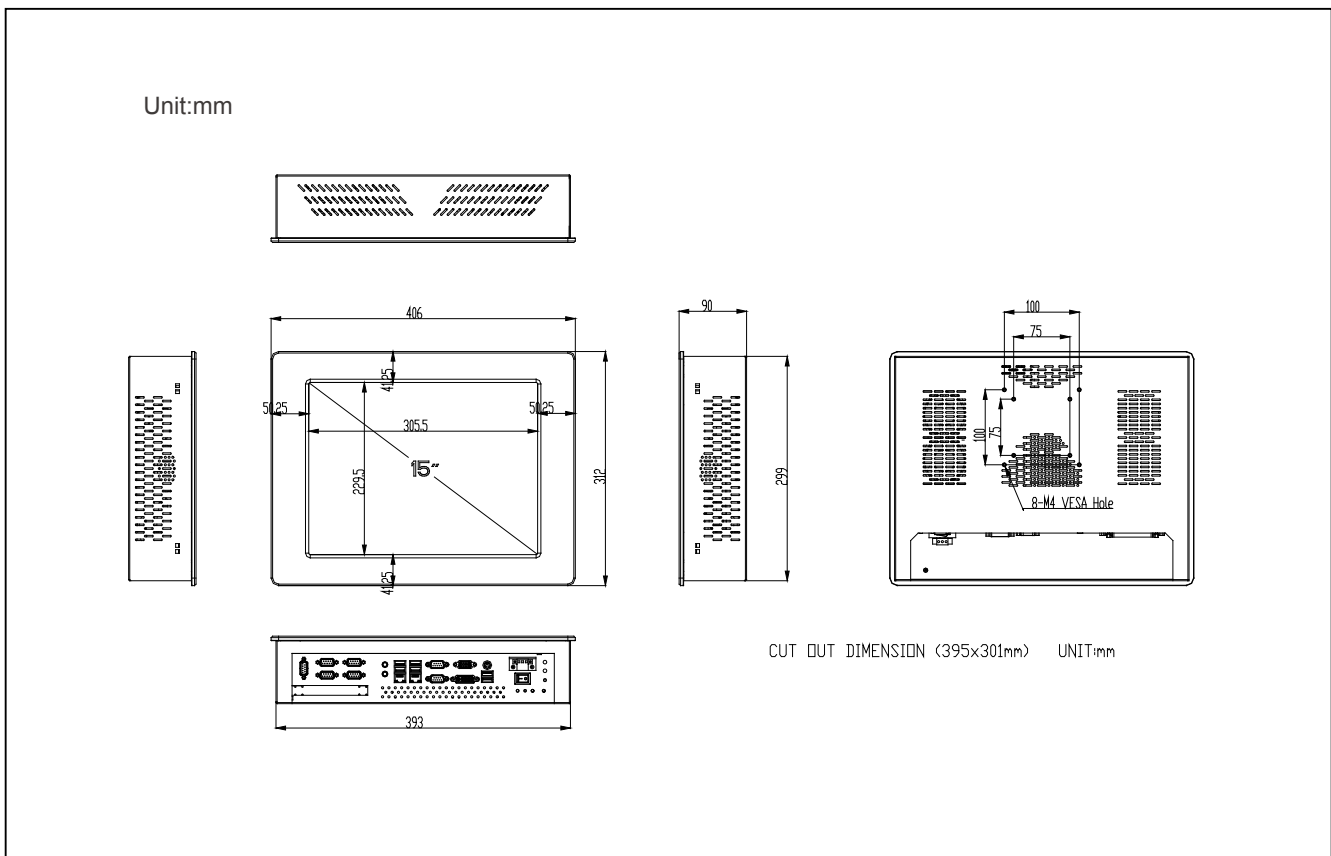

IPC-17i7

17" SXGA TFT LCD LED Backlight Intel Core i7/i5/i3
Industrial Panel PC with Touch Screen



Features

- 17" TFT SXGA LED Panel (1280 x 1024) with resistive touch screen
- Supports Intel Core i7/i5/i3 processor
- System supports 1 x DDR3 DIMM slot ,up to 8G 1066/1333MHz SDRAM
- 6x COM (1x RS485), 1xDVI, 1x PS/2, 1xVGA, 6x2.0 USB, 2xLAN, 1x AUDIO & MIC
- Offers 1xPCI Expressx16 slot and 1 xMini PCIe slot, for expansion
- Rear panel with power LED and HDD LED Indication, Built-in 2x 3 Watts stereo speaker
- Wireless LAN with antenna (optional), GPIO (optional)
- Robust aluminum with IP65 compliant front bezel design
- Modularize design for easy installation and maintenance

Specifications

Main System	
CPU	Intel Core i7/i5/i3 Sandy bridge Processor with1066/1333 MHz FSB
Chipset	Intel H61 chipset
System Memory	1x DIMM DDR3 800/1066/1333 SDRAM up to 8 GB; Preload 2GB RAM
LAN	2x Realtek ® RL8111x (Gigabit) 10/100/1000Ethernet
HDD (hard disk)	2.5" SATA HDD; Preload 320GB HDD
Audio	Realtek ® ALC662, 5.1 channel surround audio
I/O Connector	5 x RS-232 1 x RS422/485 1x DVI-D port 1x PS/2 (Keyboard/mouse) 1x DB-15 Connector 1x Audio (Mic-in / Line-out) 2x 10/100/1000MLAN port (RJ-45) 6x USB2.0 1x 3Pin DC power input terminal block
Expansion	1xPCI Express x16 Slot, 1 xMini PCIe slot
General	
Construction	Aluminum front bezel and Aluminum chassis
Color	Black or OEM(>=100 units)
OS Support	Windows 7/8/10 and linux
Mounting	Panel mount or Standard VESA 75/100mm
Power supply	Input Voltage : 8~30v, with External AC adapter; Output Rating 92W
Dimensions(WxHxD)	432 x 346 x 90mm
NET weight	9.5 KG
LCD Display	
Display type	17" SXGA TFT LCD LED Backlight
Resolution	1280 x 1024 pixels
Luminance	250 cd/m2
Viewing angle	170°(H) , 160°(V)
Touch screen	
Controller Interface	Internal USB interface controller
Resolution	Continuous
Light Transmission	81% or more
Operating Force	≤100g
Life Expectancy	35 Million

IPC-17i7

Environment

Operating Temperature	0 ~ 50°C (32 ~ 122°F)
Storage Temperature	-20 ~ 60°C (-4 ~ 140°F)
Humidity	10% to 90%@ 40°C , on-condensing
Vibration	17 to 500HZ 1G PTP
Operating Shock	1G /peak (11m sec)
Ingress Protection	Front panel: IP65

Ordering informations

IPC-17i7	17 inch Industrial Panel PC with Intel i7/i5/i3 Processor, 2.5"SATA 320G HDD(or 32G SSD) , 2G RAM(4G & 8G optional), 6*COM(5* RS232.1 * 485), 1*VGA, 1* DVI,6*USB 2.0, 2*LAN, 1* Audio, 1* MIC, 1* PS2
IPC-17i7T	17 inch Industrial Touch Screen PC with Intel i7/i5/i3 Processor, 2.5"SATA 320G HDD(or 32G SSD) , 2G RAM(4G & 8G optional), 6*COM(5* RS232.1 * 485), 1*VGA, 1* DVI,6*USB 2.0, 2*LAN, 1* Audio, 1* MIC, 1* PS2, Resistive touch screen
CPU Description	Intel® Core™ i3-3240 Processor (3M Cache, 3.40 GHz)
	Intel® Core™ i5-3470 Processor (6M Cache, up to 3.60 GHz)
	Intel® Core™ i7-3770 Processor (8M Cache, up to 3.90 GHz)

Dimensions Diagram

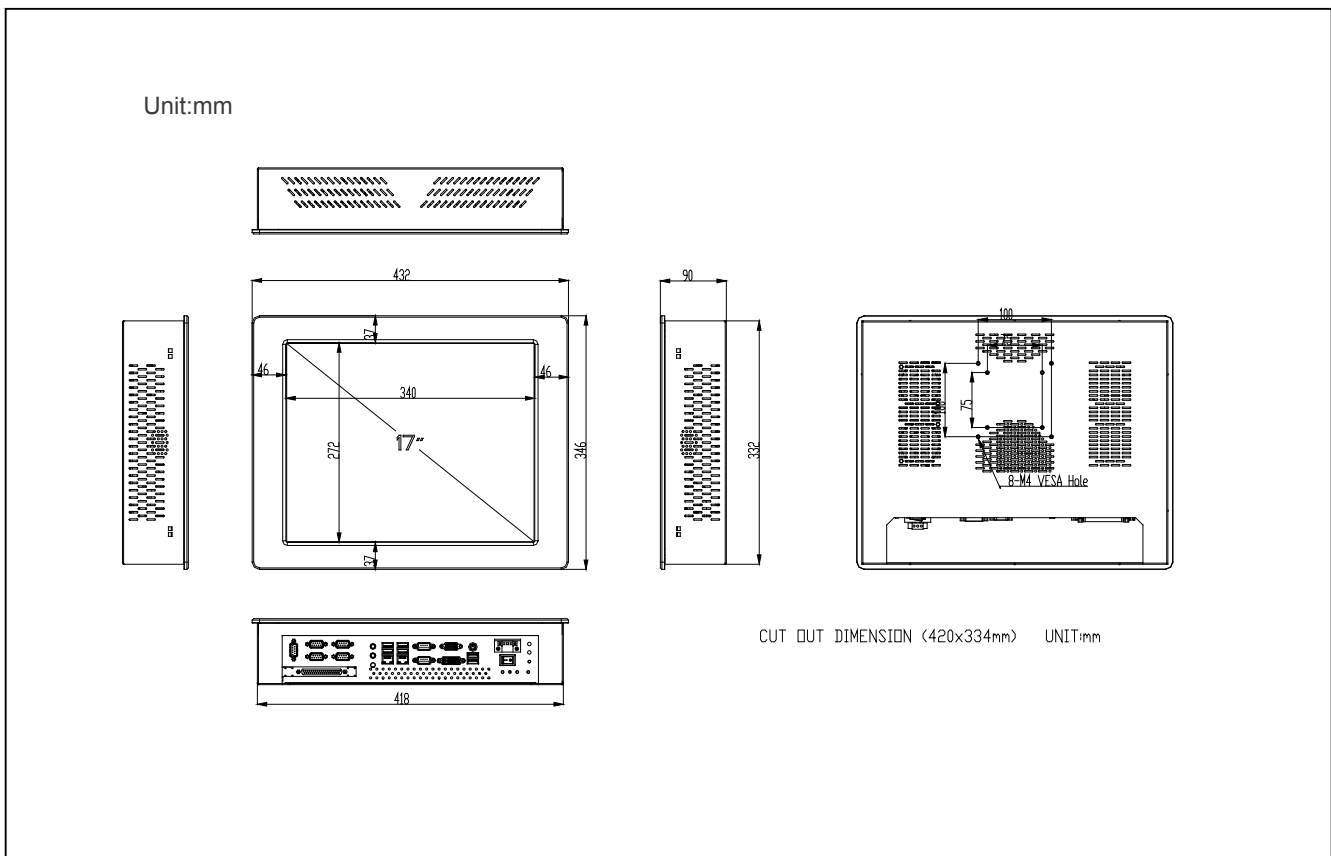

IPC-19i7

19" SXGA TFT LCD LED Backlight Intel Core i7/i5/i3
Industrial Panel PC with Touch Screen



Features

- 19" TFT SXGA LED Panel (1280 x 1024) with resistive touch screen
- Supports Intel Core i7/i5/i3 processor
- System supports 1 x DDR3 DIMM slot ,up to 8G 1066/1333MHz SDRAM
- 6x COM (1x RS485), 1xDVI, 1x PS/2, 1xVGA, 6x2.0 USB, 2xLAN, 1x AUDIO & MIC
- Offers 1xPCI Expressx16 slot and 1 xMini PCIe slot, for expansion
- Rear panel with power LED and HDD LED Indication, Built-in 2x 3 Watts stereo speaker
- Wireless LAN with antenna (optional), GPIO (optional)
- Robust aluminum with IP65 compliant front bezel design
- Modularize design for easy installation and maintenance

Specifications

Main System

CPU	Intel Core i7/i5/i3 Sandy bridge Processor with1066/1333 MHz FSB
Chipset	Intel H61 chipset
System Memory	1x DIMM DDR3 800/1066/1333 SDRAM up to 8 GB; Preload 2GB RAM
LAN	2x Realtek ® RL8111x (Gigabit) 10/100/1000Ethernet
HDD (hard disk)	2.5" SATA HDD; Preload 320GB HDD
Audio	Realtek ® ALC662, 5.1 channel surround audio
I/O Connector	5 x RS-232 1 x RS422/485 1x DVI-D port 1x PS/2 (Keyboard/mouse) 1x DB-15 Connector 1x Audio (Mic-in / Line-out) 2x 10/100/1000MLAN port (RJ-45) 6x USB2.0 1x 3Pin DC power input terminal block
Expansion	1xPCI Express x16 Slot, 1 xMini PCIe slot

General

Construction	Aluminum front bezel and Aluminum chassis
Color	Black or OEM(>=100 units)
OS Support	Windows 7/8/10 and linux
Mounting	Panel mount or Standard VESA 75/100mm
Power supply	Input Voltage : 8~30v, with External AC adapter; Output Rating 92W
Dimensions(WxHxD)	456 x 371 x 90mm
NET weight	10 KG

LCD Display

Display type	19" SXGA TFT LCD LED Backlight
Resolution	1280 x 1024 pixels
Luminance	250 cd/m2
Viewing angle	170°(H) , 160°(V)

Touch screen

Controller Interface	Internal USB interface controller
Resolution	Continuous
Light Transmission	81% or more
Operating Force	≤100g
Life Expectancy	35 Million

IPC-19i7

Environment

Operating Temperature	0 ~ 50°C (32 ~ 122°F)
Storage Temperature	-20 ~ 60°C (-4 ~ 140°F)
Humidity	10% to 90%@ 40°C , on-condensing
Vibration	17 to 500HZ 1G PTP
Operating Shock	1G /peak (11m sec)
Ingress Protection	Front panel: IP65

Ordering informations

IPC-19i7	19 inch Industrial Panel PC with Intel i7/i5/i3 Processor, 2.5"SATA 320G HDD(or 32G SSD) , 2G RAM(4G & 8G optional), 6*COM(5* RS232.1 * 485), 1*VGA, 1* DVI,6*USB 2.0, 2*LAN, 1* Audio, 1* MIC, 1* PS2
IPC-19i7T	19 inch Industrial Touch Screen PC with Intel i7/i5/i3 Processor, 2.5"SATA 320G HDD(or 32G SSD) , 2G RAM(4G & 8G optional), 6*COM(5* RS232.1 * 485), 1*VGA, 1* DVI,6*USB 2.0, 2*LAN, 1* Audio, 1* MIC, 1* PS2, Resistive touch screen
CPU Description	Intel® Core™ i3-3240 Processor (3M Cache, 3.40 GHz)
	Intel® Core™ i5-3470 Processor (6M Cache, up to 3.60 GHz)
	Intel® Core™ i7-3770 Processor (8M Cache, up to 3.90 GHz)

Dimensions Diagram

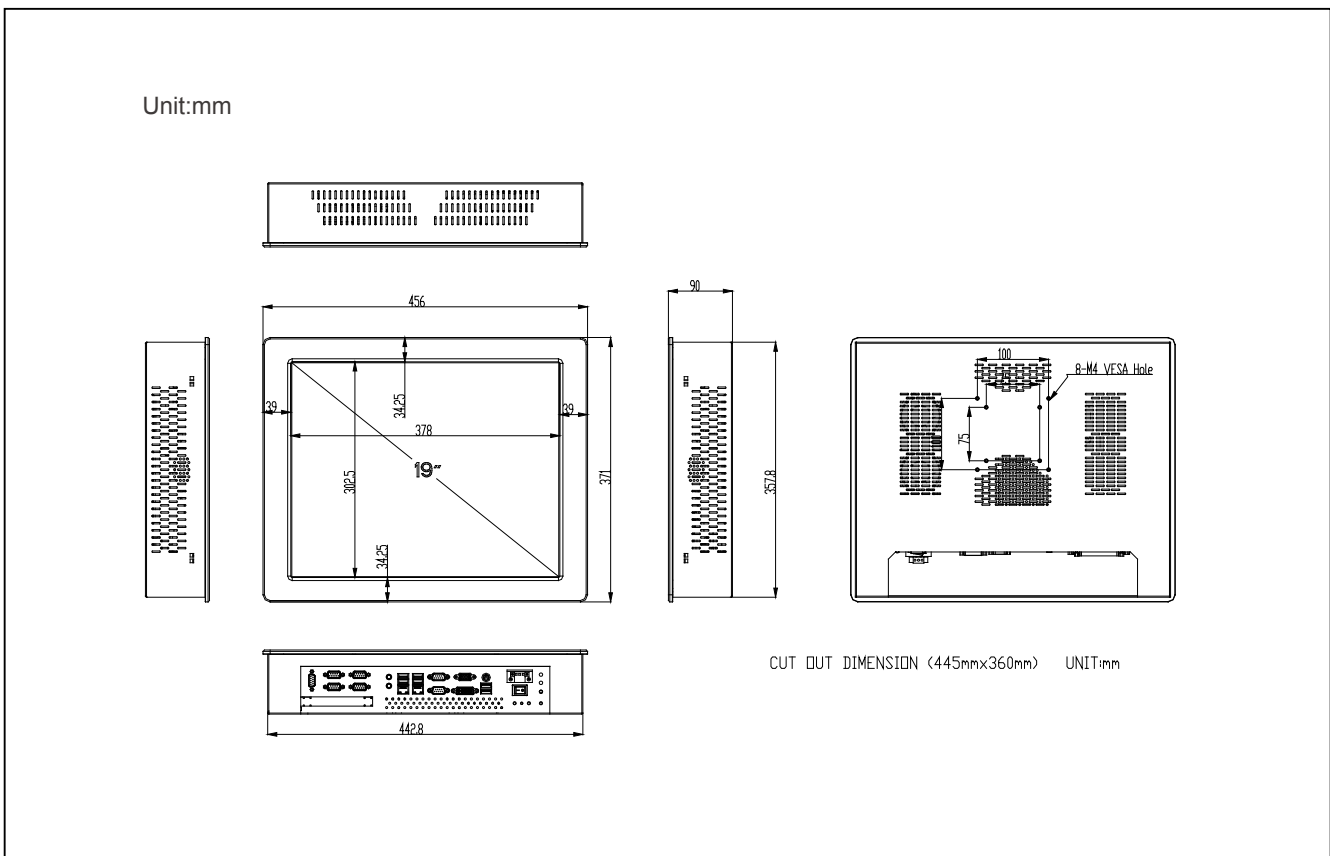

IPC-22i7

22" WSXGA TFT LCD LED Backlight Intel Core i7/i5/i3 Industrial Panel PC with Touch Screen



Features

- 22" TFT WSXGA LED Panel (1680 x 1050) with resistive touch screen
- Supports Intel Core i7/i5/i3 processor
- System supports 1 x DDR3 DIMM slot ,up to 8G 1066/1333MHz SDRAM
- 6x COM (1x RS485), 1xDVI, 1x PS/2, 1xVGA, 6x2.0 USB, 2xLAN, 1x AUDIO & MIC
- Offers 1xPCI Expressx16 slot and 1 xMini PCIe slot, for expansion
- Rear panel with power LED and HDD LED Indication, Built-in 2x 3 Watts stereo speaker
- Wireless LAN with antenna (optional), GPIO (optional)
- Robust aluminum with IP65 compliant front bezel design
- Modularize design for easy installation and maintenance

Specifications

Main System

CPU	Intel Core i7/i5/i3 Sandy bridge Processor with1066/1333 MHz FSB
Chipset	Intel H61 chipset
System Memory	1x DIMM DDR3 800/1066/1333 SDRAM up to 8 GB; Preload 2GB RAM
LAN	2x Realtek ® RL8111x (Gigabit) 10/100/1000Ethernet
HDD (hard disk)	2.5" SATA HDD; Preload 320GB HDD
Audio	Realtek ® ALC662, 5.1 channel surround audio
I/O Connector	5 x RS-232 1 x RS422/485 1x DVI-D port 1x PS/2 (Keyboard/mouse) 1x DB-15 Connector 1x Audio (Mic-in / Line-out) 2x 10/100/1000MLAN port (RJ-45) 6x USB2.0 1x 3Pin DC power input terminal block
Expansion	1xPCI Express x16 Slot, 1 xMini PCIe slot

General

Construction	Aluminum front bezel and Aluminum chassis
Color	Black or OEM(>=100 units)
OS Support	Windows 7/8/10 and linux
Mounting	Panel mount or Standard VESA 75/100mm
Power supply	Input Voltage : 8~30v, with External AC adapter; Output Rating 92W
Dimensions(WxHxD)	540 x 364 x 90mm
NET weight	11.5 KG

LCD Display

Display type	22" WSXGA TFT LCD LED Backlight
Resolution	1680 x 1050 pixels
Luminance	250 cd/m2
Viewing angle	160°(H) , 160°(V)

Touch screen

Controller Interface	Internal USB interface controller
Resolution	Continuous
Light Transmission	81% or more
Operating Force	≤100g
Life Expectancy	35 Million

IPC-22i7

Environment

Operating Temperature	0 ~ 50°C (32 ~ 122°F)
Storage Temperature	-20 ~ 60°C (-4 ~ 140°F)
Humidity	10% to 90%@ 40°C , on-condensing
Vibration	17 to 500HZ 1G PTP
Operating Shock	1G /peak (11m sec)
Ingress Protection	Front panel: IP65

Ordering informations

IPC-22i7	22 inch Industrial Panel PC with Intel i7/i5/i3 Processor, 2.5"SATA 320G HDD(or 32G SSD) , 2G RAM(4G & 8G optional), 6*COM(5* RS232.1 * 485), 1*VGA, 1* DVI,6*USB 2.0, 2*LAN, 1* Audio, 1* MIC, 1* PS2
IPC-22i7T	22 inch Industrial Touch Screen PC with Intel i7/i5/i3 Processor, 2.5"SATA 320G HDD(or 32G SSD) , 2G RAM(4G & 8G optional), 6*COM(5* RS232.1 * 485), 1*VGA, 1* DVI,6*USB 2.0, 2*LAN, 1* Audio, 1* MIC, 1* PS2, Resistive touch screen
CPU Description	Intel® Core™ i3-3240 Processor (3M Cache, 3.40 GHz)
	Intel® Core™ i5-3470 Processor (6M Cache, up to 3.60 GHz)
	Intel® Core™ i7-3770 Processor (8M Cache, up to 3.90 GHz)

Dimensions Diagram

